

(No Model.)

4 Sheets—Sheet 1.

S. HARRIS.
AXLE MACHINE.

No. 437,029.

Patented Sept. 23, 1890.

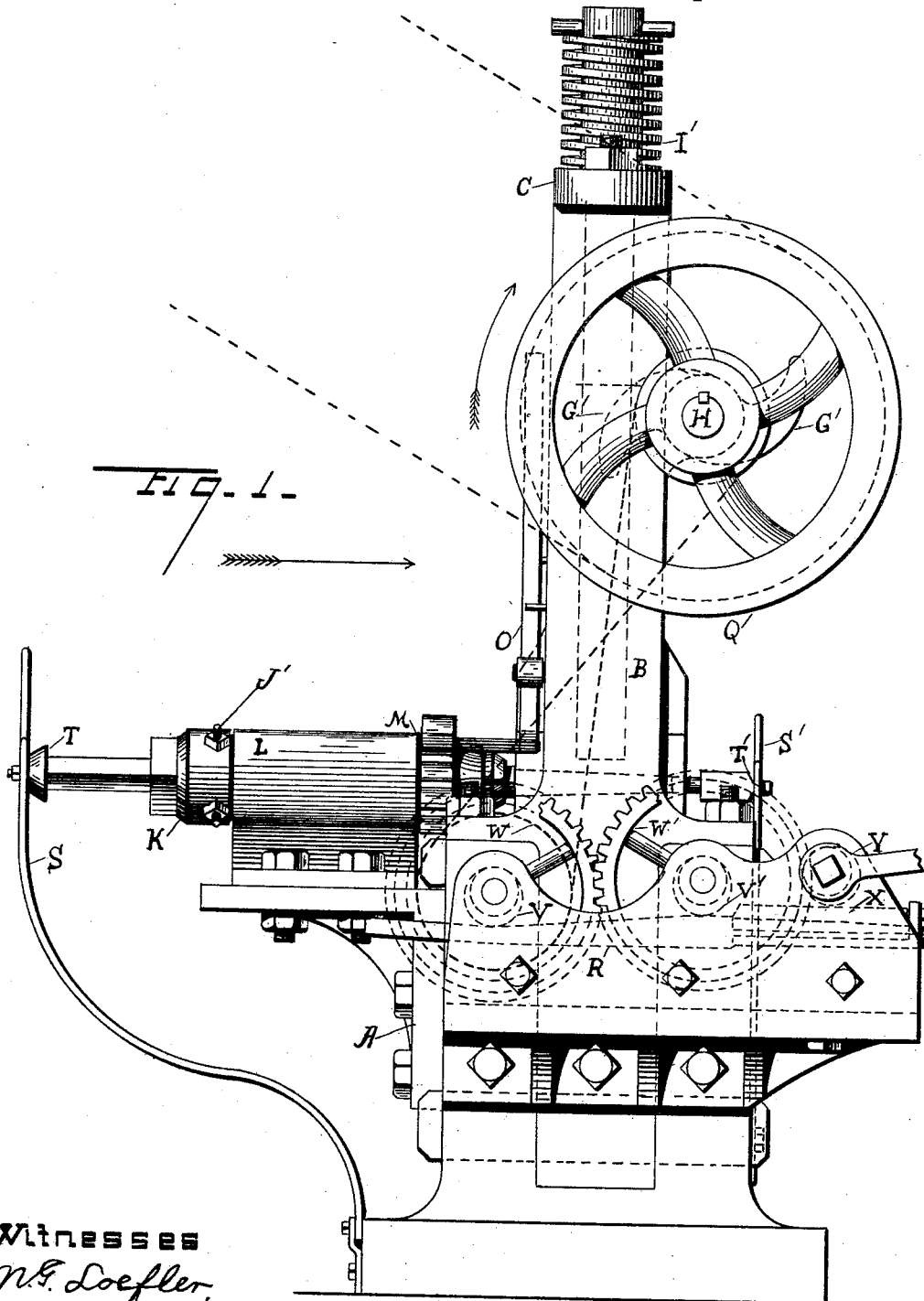

Witnesses
M. F. Loeffler.
A. H. Le Marie

Inventor
S. Harris
by *J. M. Doone*
ATTORNEY

S. HARRIS.
AXLE MACHINE.

No. 437,029.

Patented Sept. 23, 1890.

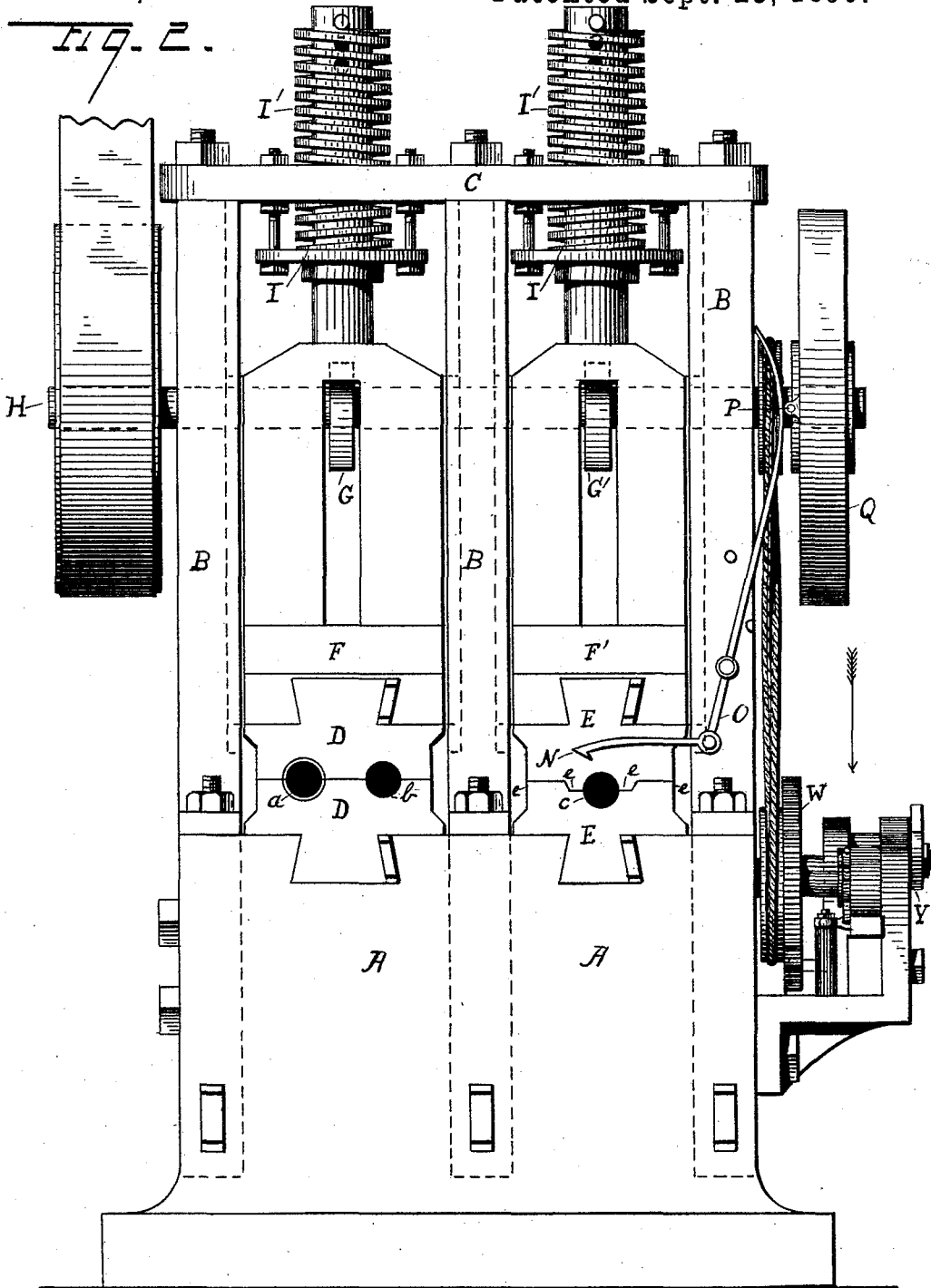

Witnesses
M. S. Loefler,
A. H. St. Marie

Inventor
Sylas Harris
 by *Wm. L. Boone*
 Attorney

S. HARRIS.
AXLE MACHINE.

No. 437,029.

Patented Sept. 23, 1890.

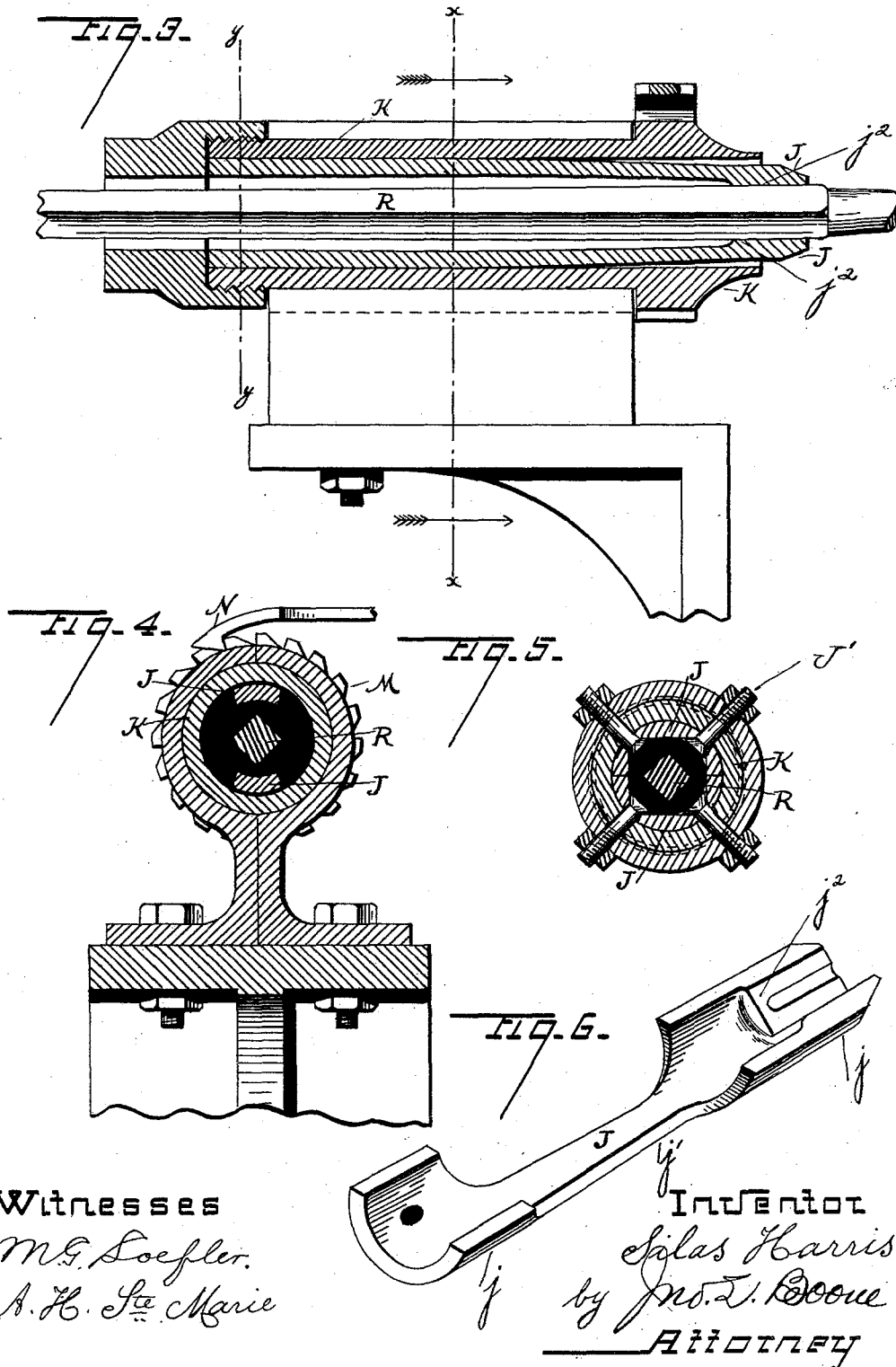

Witnesses
M. G. Soepler.
A. H. La Marie

Inventor
Silas Harris
 by *W. T. Boone*
 Attorney

S. HARRIS.
AXLE MACHINE.

No. 437,029.

Patented Sept. 23, 1890.

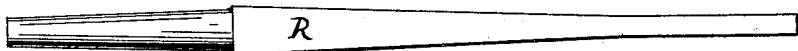
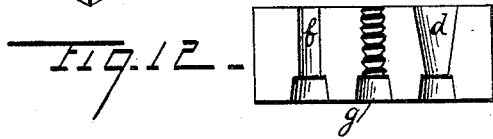
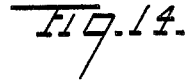
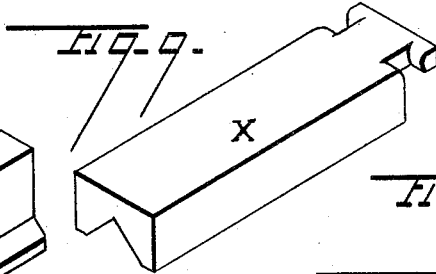
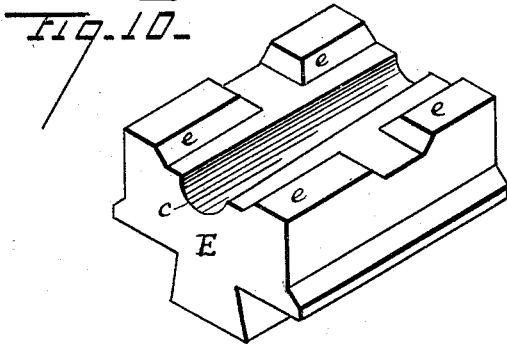
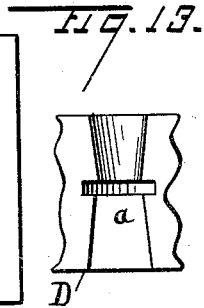
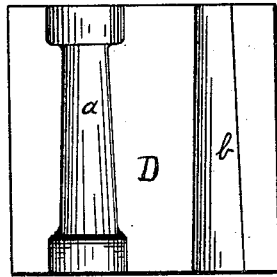
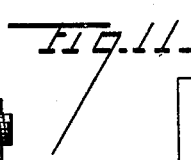
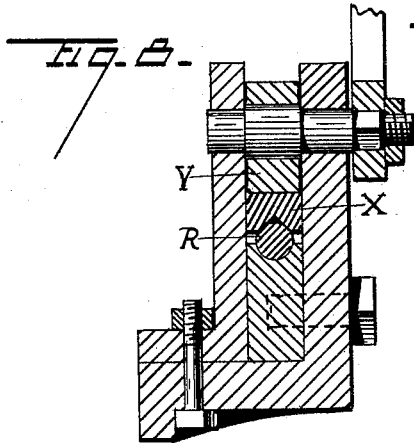
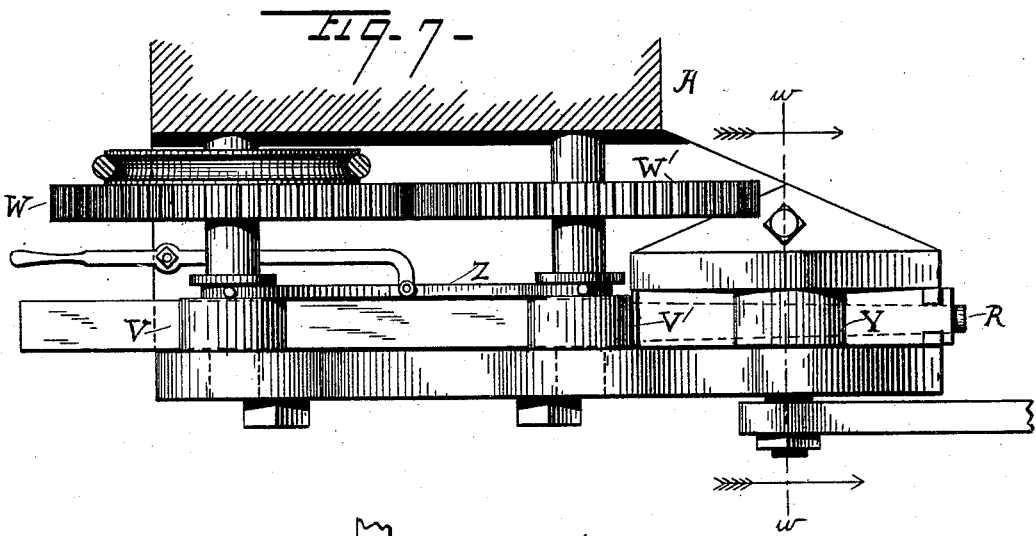

Witnesses
 M. G. Soefler.
 A. H. La Marie

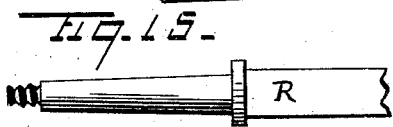

Inventor
 Silas Harris
 by J. W. Deane
 Attorney

UNITED STATES PATENT OFFICE.

SILAS HARRIS, OF SAN FRANCISCO, CALIFORNIA.

AXLE-MACHINE.

SPECIFICATION forming part of Letters Patent No. 437,029, dated September 23, 1890.

Application filed February 15, 1890. Serial No. 340,600. (No model.)

To all whom it may concern:

Be it known that I, SILAS HARRIS, a citizen of the United States, residing at San Francisco, in the county of San Francisco and State of California, have invented certain new and useful Improvements in Axle-Machines; and I do hereby declare the following to be a full, clear, and exact description of said invention, such as will enable others skilled in the art to which it most nearly appertains to make, use, and practice the same.

The object of my invention is to produce wagon or car axles completely finished and ready for use by forging and without the use of a lathe.

I have discovered that by subjecting a heated bar to a preliminary roughing operation under a trip-hammer it can afterward be formed, shaped, and rounded in a suitable forging mechanism, whereby a journal is completely finished and shaped with a forged surface as smooth as glass, thus producing a wagon or car journal which is far superior to the journals turned in a lathe. My invention therefore relates to a machine which is adapted to rough, shape, form, and finish a wagon-axle by a succession of dies and hammers, so that the heated bar can be operated upon and passed from one die to the other during a single heat, if preferred, and thus be completed ready for use.

Referring to the drawings herewith, forming part of this specification, Figure 1 is a side elevation of my improved axle-machine; Fig. 2, a front elevation of the same with the lower front part removed; Fig. 3, a sectional side elevation of that part through which the axle is inserted and by which it is held; Fig. 4, a cross-section taken from line *x x*, Fig. 3, looking in the direction of the arrow; Fig. 5, also a cross-section taken from line *y y*, same figure, looking the same way; Fig. 6, a perspective view of one of the axle-grippers; Fig. 7, a plan of the axle-seat; Fig. 8, a cross-section taken from line *w w*, Fig. 7, looking toward the right; Fig. 9, a perspective view of a block used for holding the axle in place while being set; Fig. 10, a detail view in perspective of one of the finishing-dies; Fig. 11, a plan of the roughing and shaping dies for plain axles; Fig. 12, a detail view of a plain

axle when taken from the finishing-dies; Fig. 13, a plan of the roughing-dies for solid-collared axles; Fig. 14, a plan of the dies where the neck of the axles is formed and the thread forged on, and Fig. 15 a broken view of a solid-collared axle completely finished.

Let A represent the base of the machine, and B standards rising therefrom and united by a beam C at their top. Upon the base between the standards are matching dies D E, the upper one of which is secured to drop-hammers F F', operated by cams G G' on the shaft H. By preference the cams G, working the hammer F, are three in number, (one only, however, being shown in the drawings,) while two are sufficient to operate the hammer F', it being advisable to work the roughing and shaping dies D faster than the finishing-dies E. These two last-mentioned cams are shown by dotted lines in Fig. 1, from which it will be seen that the cams project radially from the shaft H.

It is very important to strike quick blows with the hammers in order to produce a very smooth axle-journal. This very desirable effect I obtain in my machine by confining the shank of the hammers within spiral springs I I', located above and below the beam C, as illustrated in Fig. 2. As will be noticed, the springs I are compressed when the springs I' are distended, and the reverse, and this arrangement I have found by experience to produce most satisfactory results.

Detail views of the roughing, shaping, and finishing dies are shown at Figs. 10, 11, and 13, where it can be seen that the die-grooves *a b c*, wherein the axle-journal is formed, are gradually reduced in size, the axle being passed through each in the order named. I have not shown in the accompanying drawings the mode through which the rectangular part of the axle is formed, as this is an elementary process involving no invention and may be carried out in various ways, either by rolling, striking with a steam-hammer, or stamping with an extra die added to my machine, as preferred. The most important part of an axle and the one requiring the most expertness in making is the journal, and it is better for the present purpose to confine any description to the treatment of this part. Hav-

ing then formed the rectangular part of the axle, as just stated, I pass its ends through the groove *a* of the dies D and subject it to the roughing operation, turning the axle by hand while it is struck. Of course, if it be a plain axle, I use the die represented in Fig. 11; if a solid collared one the die shown at Fig. 13. The axle having undergone the roughing operation, I next work it in the groove *b* of the same dies D, when the journal is given the proper shape, the turning of the axle being here again done by hand, and after I have thus shaped the journal I finally pass it through the dies E, where it is reduced to the proper size and finished.

Opposite the end of the groove *c* of the matching dies E and in front of the machine I mount a peculiar device for holding and turning the axle while the journal is being finished, as represented in Fig. 1. It is composed of a pair of grippers J, (see Figs. 3, 4, 5, and 6,) secured to the inner sides of a cylinder K and adapted to be revolved with the latter within an outer shell L by means of a toothed wheel M, hook N, and pivoted lever O, actuated by cams or rollers P, projecting inwardly from the fly-wheel Q. It will be seen that these grippers are provided with enlarged concaved ends *j j*, connected by a central web *j'*, and their rear ends are provided with inner enlargements *j² j²*, as shown in Figs. 3 and 6, which when the axle is inserted bear against the rear end thereof and support the same. It will also be noticed that the grippers are secured to the inner surface of the cylinder K by means of bolts J'.

The axle R is inserted between and held by the grippers J in such a position that its journal may lie within the matching dies and its ends abut against springs S S', secured, respectively, to the front and rear of the machine. The front spring S is stronger than the rear spring S', so that the yielding of the latter may permit the expansion of the metal stamped out in its direction. Caps T T', pivoted to these springs, prevent them from slipping off the ends of the axle when it is turned.

As previously stated, the axle-journal is first roughed and shaped in the grooves or chambers *a b* of the dies D and then finished in the groove *c* of the dies E. It does not matter much if the dies D fit accurately together or not, as the axle is withdrawn from them in a rather rough state; but it is important that the dies E match perfectly, in order that the axle-journal be completely finished when taken out of the latter. This I effect by providing the faces of the dies E with projections *e* and corresponding depressions, as shown at Figs. 2 and 10. These dies are thus rendered self-guiding and constantly kept in a true position relatively to each other, and I am enabled through their use and by a continual and regular automatic rotation of the axle-journal while being struck, as hereinbefore set forth, to finish an axle solely by stamping or forging without the use of a lathe.

The axle shown at Fig. 12 and elsewhere in the drawings is a plain axle; but it is evident that a full-collared axle, such as is shown at Fig. 15, may be made with my machine just as well by simply using the proper kind of dies—that is to say, dies having a groove *a*, as in Fig. 13, and a groove *b*, as in Fig. 11.

The neck of the axle and the thread at its extreme end I forge by means of dies, such as are shown at Fig. 14, the end of the journal being passed successively through the grooves *d*, *f*, and *g*. These dies are used either on my machine, by substituting them, for instance, for the other dies or adding an extra hammer, or on another machine similarly operated.

It has been customary to pass the axle through another machine in order to give it the proper set; but as this process leads to some inconvenience I prefer setting it on the same machine I use for the forging. I therefore lay the axle, after it has been withdrawn from the finishing-dies, onto a support at the right of the machine under eccentric-rollers V V', operated by the geared wheels W W', Fig. 7, to which motion is imparted from the shaft H, Fig. 1. The rollers V V' revolve in opposite directions, pressing on the axle inwardly, so that the latter may not slip out of place. A block X, (see Figs. 8 and 9,) set upon the axle-journal and pressed down by another eccentric Y, further helps to maintain the axle true while set. A clutch Z brings the rollers V V' into operation, and it is calculated that the axle will be properly set at a single turn of the eccentrics. I thus produce an axle from a blank by passing it through one single machine and thereby effect a great saving in time. The chief advantage of my invention, though, consists in that I avoid the use of the lathe. It is a fact admitted by all iron-workers that the lathe takes off the best of the metal, which lies on the outside, whereas by my stamping process the metal is compressed and hardened and enables me to manufacture axles of superior excellence.

I am aware that dies and machines for forging axles have been constructed prior to my invention; but, so far as known to me, none have ever been devised so as to turn out a complete axle which does not require finishing on the lathe.

I therefore claim—

1. In an axle-machine, the combination, with dies, of grippers for engaging the axle, said grippers having enlarged concaved ends with a central web and their rear ends provided with inner enlargements adapted to bear against the inner end of the axle, substantially as set forth.

2. In an axle-machine, the combination of dies, grippers for engaging the axle, a cylinder surrounding the same and carrying upon its inner end a toothed wheel, an outer shell surrounding the cylinder, a hook and pivoted lever, and a fly-wheel provided with cams or rollers for engaging the pivoted lever, substantially as set forth.

3. In an axle-machine, the combination of a die consisting of upper and lower sections, the matrices thereof being of varying diameter, whereby the axle is roughened and shaped, in combination with means for operating the die, substantially as set forth.

4. In an axle-machine, the combination, with the dies thereof, of front and rear springs and caps pivoted to said springs for engaging the ends of the axle, substantially as set forth.

5. In an axle-machine, the combination of a frame provided with an axle-support, shafts having eccentrics thereon for engaging the axle, and means for rotating said shafts in opposite directions, substantially as set forth.

6. In an axle-machine, the combination of a frame provided with an axle-support, a main shaft carrying a belt-pulley thereon, short shafts carrying suitable cog-wheels and also having mounted thereon eccentrics for engaging the axle, a pulley-belt connecting one of the short shafts with the pulley-wheel of the main shaft, and clutch mechanism for throwing the cog-wheels into gear, substantially as set forth.

7. In an axle-machine, the combination of a frame provided with an axle-support, shafts having eccentrics mounted thereon for engaging the axle, means for rotating the shafts in opposite directions, a block bearing upon the axle-journal, and a rear short shaft provided with an eccentric for engaging said block, substantially as set forth.

8. In an axle-machine, the combination of a frame having end and central standards extending therefrom, a cross-beam uniting said standards at their upper ends, dies lo-

cated upon one side of the machine, the faces or sections thereof being provided with grooves for roughening and shaping the axle, a hammer secured to the upper section or face of said die and having its shank passing through the cross-beam, dies upon the opposite side of the machine for finishing the axle, a hammer connected to the upper section of said last-named die and having its shank passing through the cross-beam, brackets depending from said cross-beam, a main shaft having a pulley-wheel upon one end and a fly-wheel upon the opposite end, coiled springs encircling the shanks of the hammers below the cross-beam and seated upon the brackets, coiled springs above the cross-beam, and cams upon the main shaft for operating the hammers, substantially as set forth.

9. In an axle-machine, the combination of dies, a cylindrical casing for the axle carrying upon its inner end a toothed wheel, and an actuating-hook for engaging said toothed wheel, substantially as set forth.

10. In an axle-machine, the combination, with the dies thereof, of front and rear springs for engaging the ends of the axles, said rear spring having greater resiliency than the former, so that the yielding thereof may permit the expansion of the metal stamped out in its direction, substantially as set forth.

In testimony whereof I have hereunto affixed my signature in the presence of two witnesses.

SILAS HARRIS.

In presence of—

A. H. STE. MARIE,
M. E. LOEFLER.